

PORCH-LIFT®
VERTICAL PLATFORM LIFT

Planning Guide

for PL-S Standard Model in a Hoistway
for Architects and Lift Contractors

April 10, 2007

ThyssenKrupp Access
Accessibility Division



ThyssenKrupp

Introduction

This Planning Guide is designed to assist architects, contractors, building owners and lift contractors in planning for a Porch-Lift® vertical platform lift that meets the requirements of ASME A18.1.

We strongly recommend you contact the codes authority having jurisdiction in the area(s) where the wheelchair lift will be installed. Become familiar with all requirements governing the installation and use of wheelchair lifts. It is extremely important for you to know and adhere to all regulations concerning installation and use of wheelchair lifts.

IMPORTANT NOTICE:

This Planning Guide provides nominal dimensions and specifications useful for INITIAL planning of a wheelchair lift project. BEFORE beginning actual construction, be sure to receive application drawings customized with specifications and dimensions for your specific project. Call 1-800-829-9760 to find a dealer in your area.

Wheelchair lift configurations and dimensions are in accordance with our interpretation of the standards set forth by ASME A18.1. Please consult ThyssenKrupp Access or an authorized dealer in your area for more specific information pertaining to your project, including any deviation between referenced standards and those of any local codes or laws. Always contact local codes authorities for any variation to standards.

The dimensions and specifications in this Planning Guide are subject to constant change (without notice) due to product enhancements and continually evolving codes and product applications.

Contents

Porch-Lift overview	3
Drive systems	4
Model heights	4
Power requirements.....	4
Hoistway layouts	5-6
Door and gate details	7-9
Mounting details	10
Static anchoring load calculations	11
Features	12-13
3-Part specifications.....	14-15

Porch-Lift overview

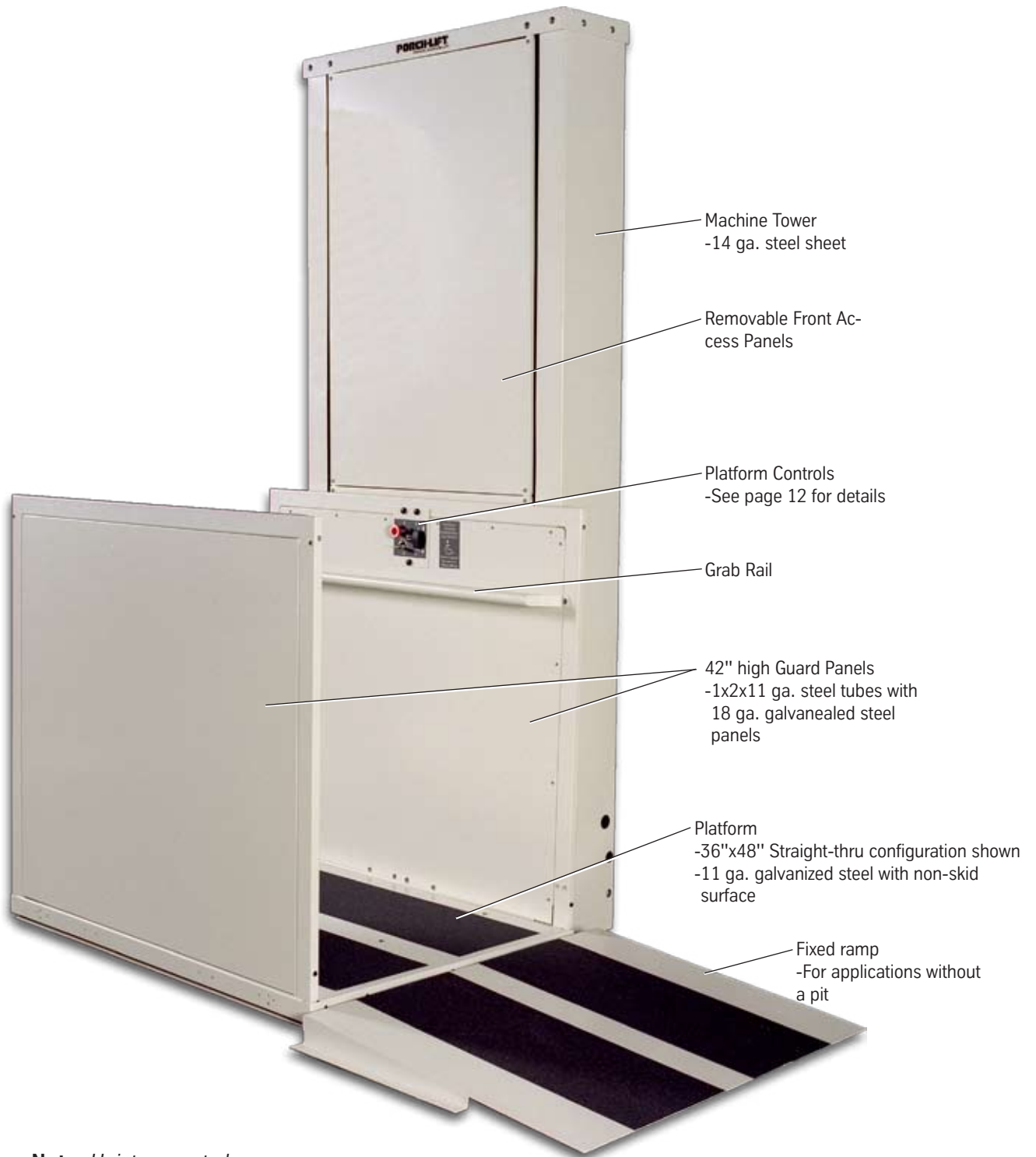

Note: Hoistway not shown.

Drive systems Three drive systems to choose from:

AC powered ballscrew drive

1/2 hp motor, 120 V, 60 Hz, reversible
Electromechanical brake
Single V-belt drive system with monitoring switches
Ballscrew safety nut
Manual lowering device
Speed with rated load: 9-12 fpm

Battery powered ballscrew drive -

1/2 hp motor, 24 VDC, reversible
Two 12 V, 33 AH, sealed no maintenance batteries with 24 V, 1.7 amp Smart Charge™ battery charger
Electromechanical brake
Ballscrew safety nut
Manual lowering device
Speed with rated load: 9-12 fpm

Battery powered hydraulic drive -

3/4 hp pump motor, 24 VDC, 0.83 gpm @ 1500 psi pump with relief switch
Two 12 V, 33 AH, sealed no maintenance batteries with 24 V, 3.3 amp Smart Charge™ battery charger
Aircraft hydraulic fluid
Manual emergency lowering relief valve
1:2 Roped hydraulic single stage 42mm cylinder with line rupture valve
Two 3/8" diameter aircraft ropes
Broken rope safety device
Speed with rated load: 18-21 fpm

General equipment on all drive systems -

750 lbs. Rated load
2 or 3 Landings
Relay logic motor controls
Constant pressure, low voltage controls; paddle switch with key operation and emergency stop with alarm
Platform safety pan
42" High guard panels on platform with grab rail
36"x48", 36"x56" or 36"x60" Platform with non-skid surface
Final limit switches
ETL and UL Listed when lifting height is 144" or less
2 years drive train and 1 year limited warranty on all other component parts

Model

The model height required for a particular application is determined by the "lifting height", which is the vertical distance between the upper landing and the bottom of the lift. (See illustrations to the right.)

If the lift is not mounted in a pit, a stationary ramp is required outside of the hoistway. A fixed ramp is provided as standard equipment. (See details on page 13.)

MODEL	MAXIMUM LIFTING HEIGHT	MACHINE TOWER HEIGHT
PL-S 36	3'-3"	59 ¹ / ₄ "
PL-S 50	4'-5"	73 ¹ / ₄ "
PL-S 72	6'-3"	95 ¹ / ₄ "
PL-S 96	8'-3"	119 ¹ / ₄ "
PL-S 120	10'-3"	143 ¹ / ₄ "
PL-S 144	12'-3"	167 ¹ / ₄ "
PL-S 168*	14'-3"	191 ¹ / ₄ "

* Local or state variance required if travel of platform exceeds 12'-0".

Machine tower is 38¹/₂" wide, the tower cap is 39" wide.

Lift Height is measured from base of unit

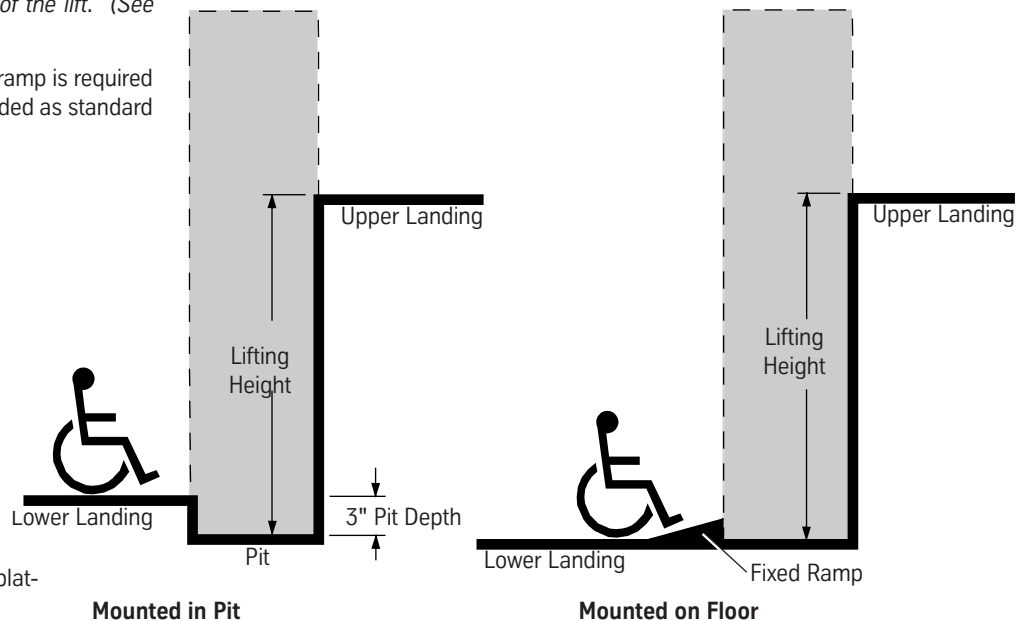

Power requirements

115 VAC, single phase, 20 amp, 60 Hz power circuit required to be supplied by others.

Note: Battery powered lifts must be connected to the AC power source to charge the batteries.

Hoistway layout Straight-thru platform

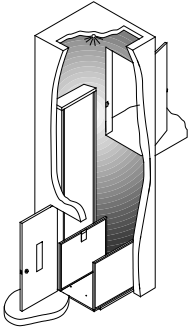

3 Sizes: 36" x 48" (standard)
36" x 56"
36" x 60"

Available with 2 or 3 stops.

6'-8" minimum above top landing floor required for overhead clearance.

* Doors and gates are to be centered on the platform opening. See door and gate details for construction openings.

Note: Overall dimensions and running clearances conform to ASME-A18.1. Dimensions are to finished walls.

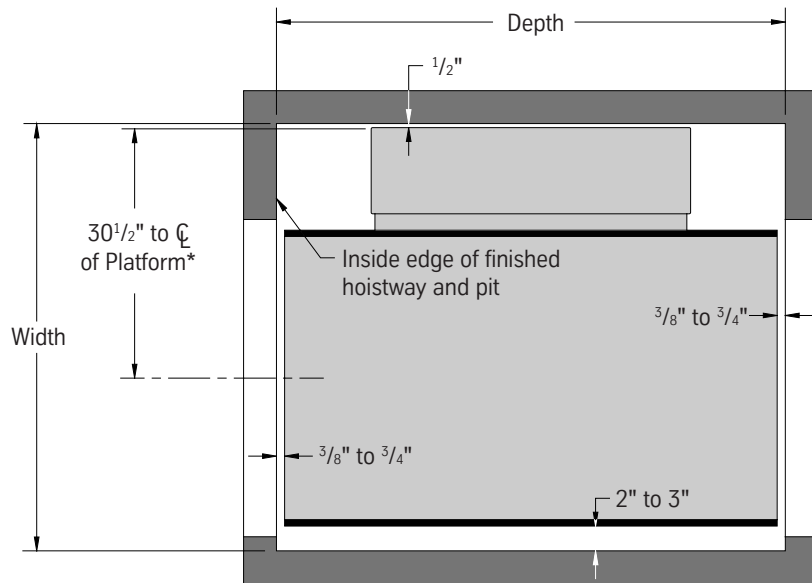

Platform Size	Hoistway dimensions	
	Width	Depth
36" x 48"	51 to 52"	48 ³ / ₄ " to 49 ¹ / ₂ "
36" x 56"	51" to 52"	56 ³ / ₄ " to 57 ¹ / ₂ "
36" x 60"	51" to 52"	60 ³ / ₄ " to 61 ¹ / ₂ "

Hoistway layout 90° Exit platform

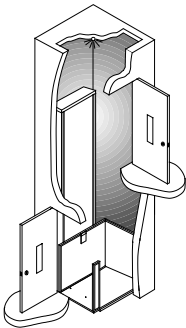

4 Sizes: 36" x 48" (standard)
36" x 56"
36" x 60"
42" x 60" – clear

Available with 2 or 3 stops. (On 3 stop lifts, the top landing door or gate must be on the wide side of the platform.)

6'-8" minimum above top landing floor required for overhead clearance.

* Doors and gates are to be centered on the platform opening. See door and gate details for construction openings.

Note: Overall dimensions and running clearances conform to ASME-A18.1. Dimensions are to finished walls.

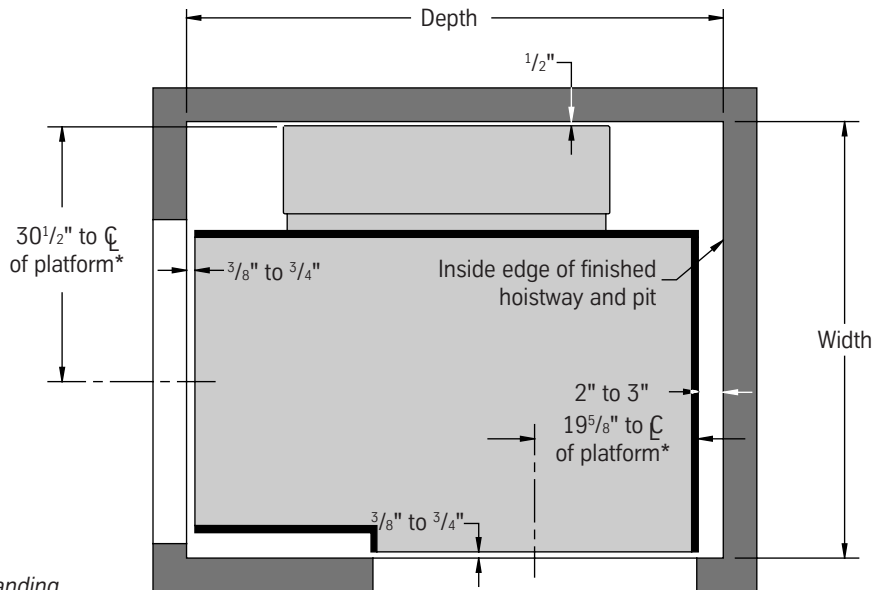

Left hand configuration shown, right hand opposite.

Platform Size	Hoistway dimensions	
	Width	Depth
36" x 48"	51 ³ / ₈ " to 51 ³ / ₄ "	50 ³ / ₈ " to 51 ³ / ₄ "
36" x 56"	51 ³ / ₈ " to 51 ³ / ₄ "	58 ³ / ₈ " to 59 ³ / ₄ "
36" x 60"	51 ³ / ₈ " to 51 ³ / ₄ "	62 ³ / ₈ " to 63 ³ / ₄ "
42" x 60"	59 ³ / ₈ " to 59 ³ / ₄ "	63 ³ / ₈ " to 64 ³ / ₄ "

Hoistway layout Enter/exit same side

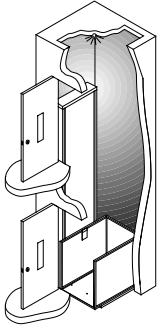

3 Sizes: 36" x 48" (standard)
36" x 56"
36" x 60"

Lifting height must be a minimum of 8'-0".

Available with 2 stops only.

6'-8" minimum above top landing floor required for overhead clearance.

* *Doors and gates are to be centered on the platform opening. See door and gate details for construction openings.*

Note: *Overall dimensions and running clearances conform to ASME-A18.1. Dimensions are to finished walls.*

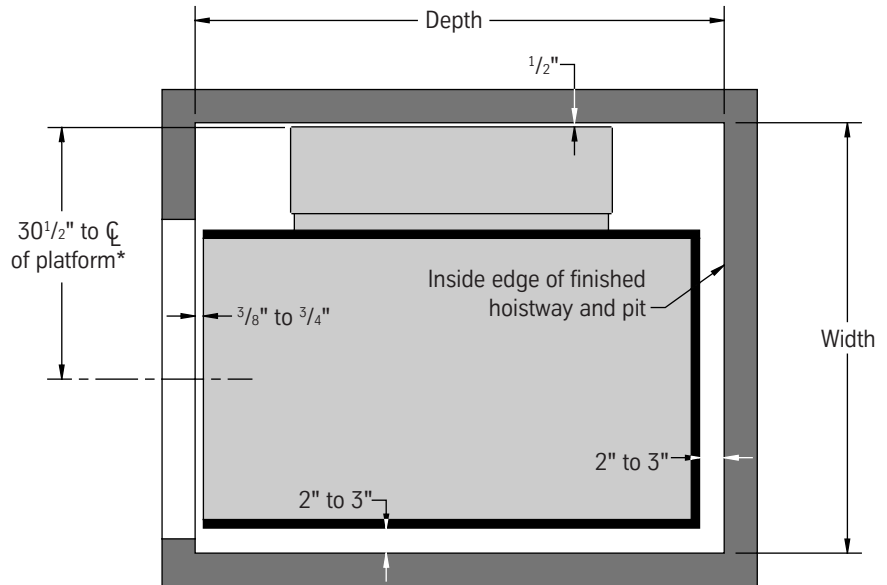

Left hand configuration shown, right hand opposite.

Platform Size	Hoistway dimensions	
	Width	Depth
36" x 48"	51" to 52"	50 ³ / ₈ " to 51 ³ / ₄ "
36" x 56"	51" to 52"	58 ³ / ₈ " to 59 ³ / ₄ "
36" x 60"	51" to 52"	62 ³ / ₈ " to 63 ³ / ₄ "

Doors

Fire rated door with VDR™ interlock

- 1½ hour 'B' label fire rating.
- Constructed of steel sheet metal, primed for painting at jobsite.
- Hoistway side of door and frame is mounted flush with the hoistway wall.
- U.L. Listed mechanical interlock included inside door frame.
- Call/send control can be mounted in the door frame adjacent to the door pull (optional).
- 4' wide 6'8" tall door available for 90° units
- 3' wide 6'8" tall door standard

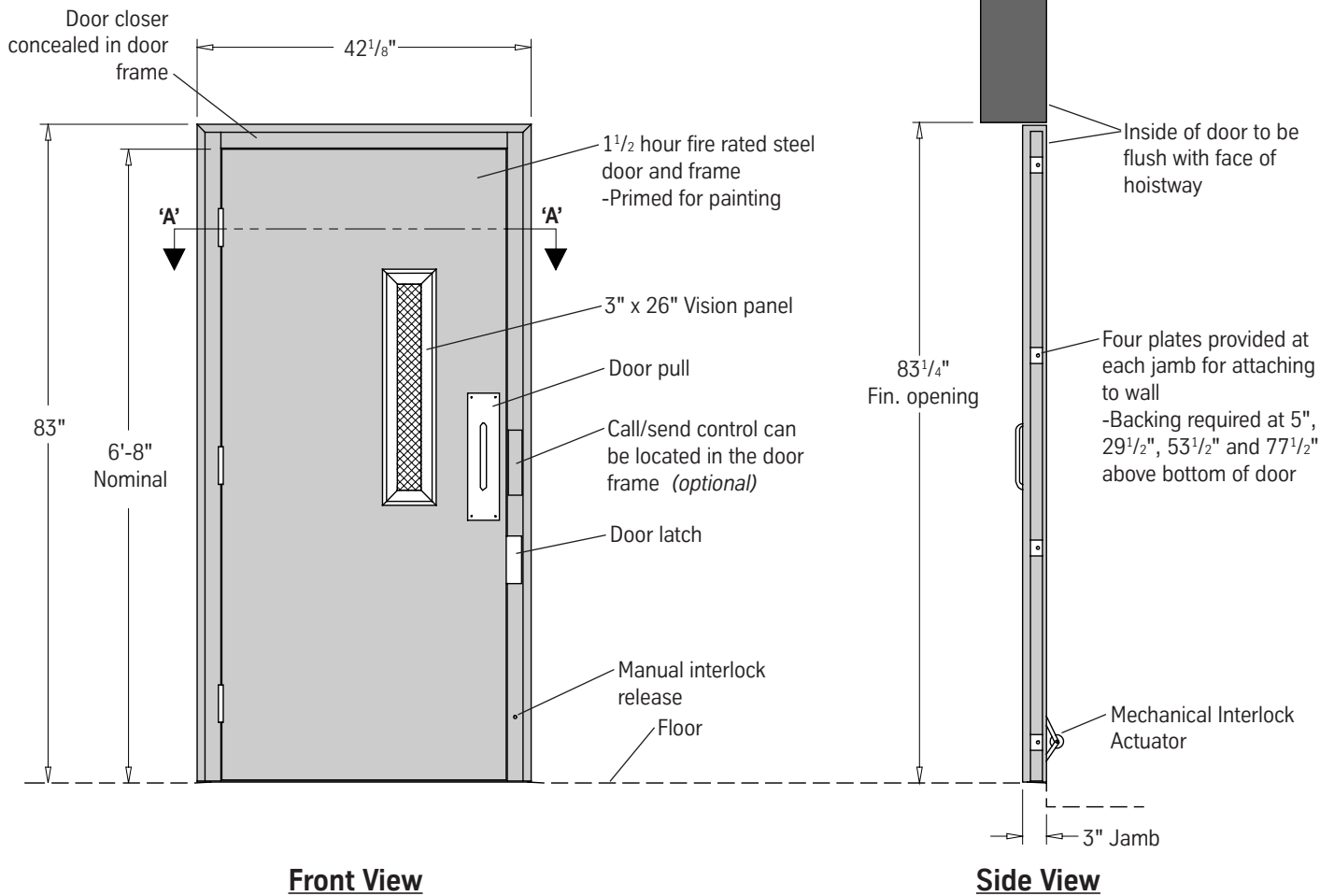
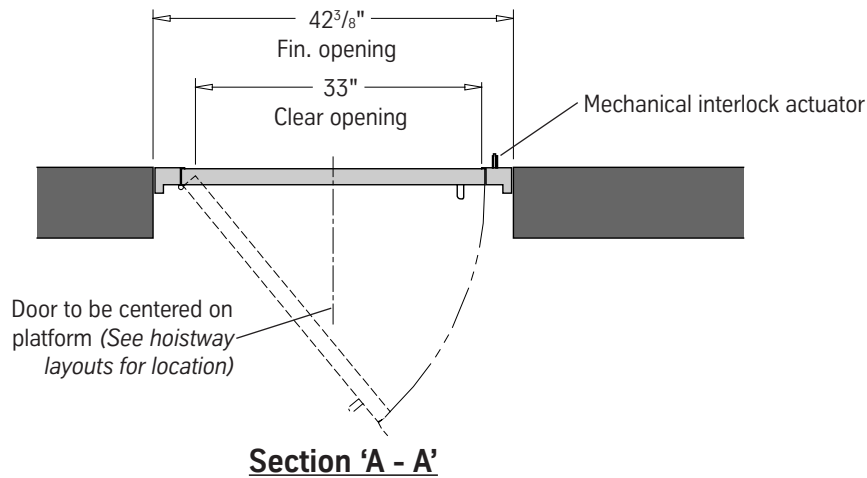

Non-fire rated door with VDR™ interlock (similar to door on the model PL-ENC Enclosure)

- Constructed of structural aluminum extrusions, powder coated finish.
- Hoistway side of door and frame is mounted flush with the hoistway wall.
- UL listed mechanical interlock included inside door frame.
- Call/send control can be mounted in the door frame adjacent to the door pull (optional).
- Available with Von-Duprin electric strike.

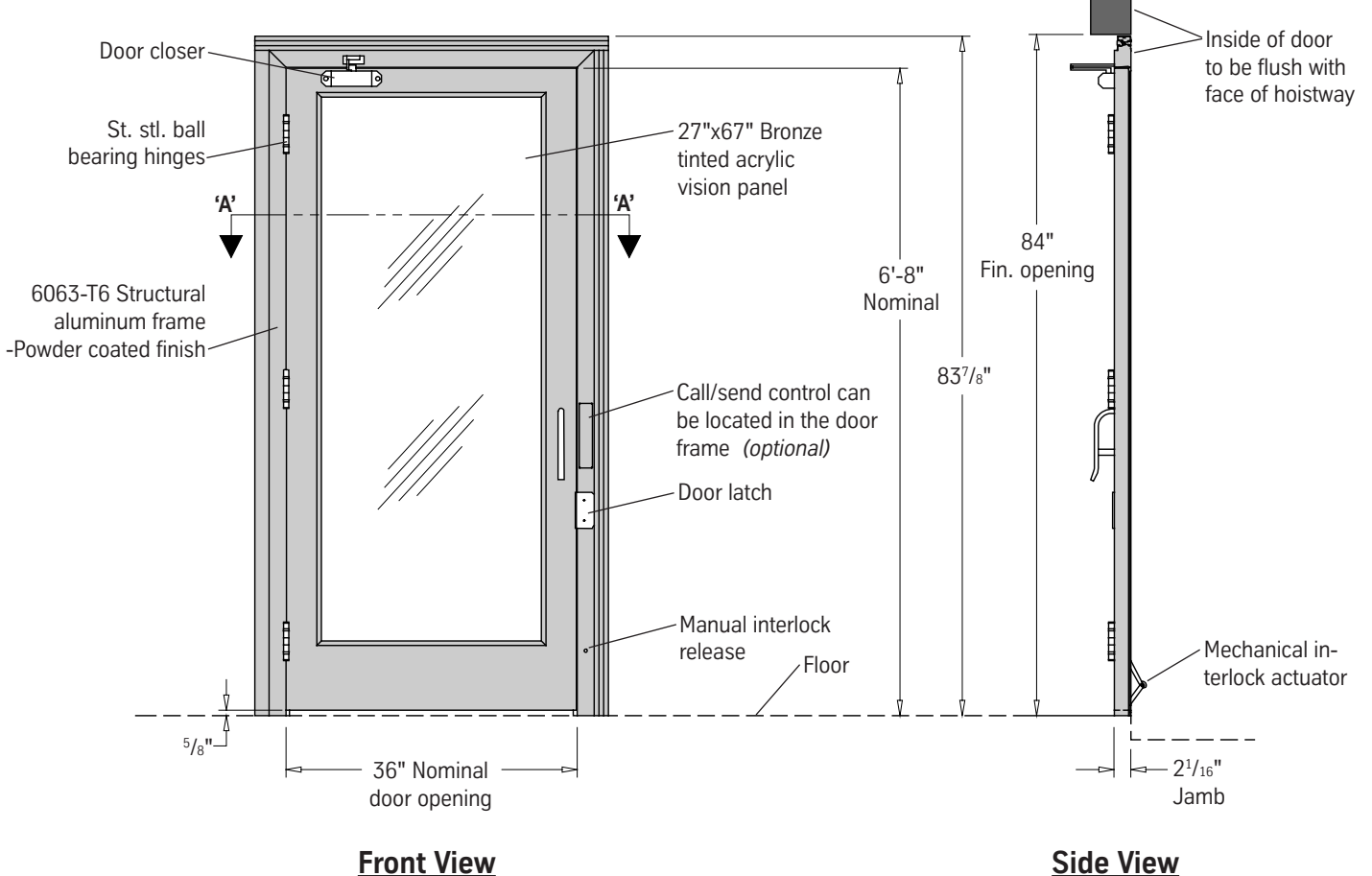
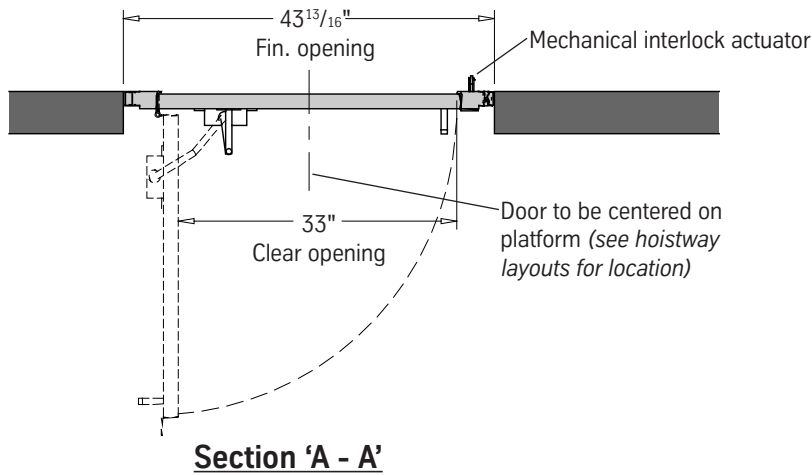

Top landing gate with VDR™ interlock

- Hoistway side of gate and frame is mounted flush with the hoistway wall.
- UL listed mechanical interlock included inside door frame.
- Call/send control can be mounted in the gate frame adjacent to the door pull (optional).
- An extra wide 43" and 49" gate can be provided for use with a 90° exit platform.

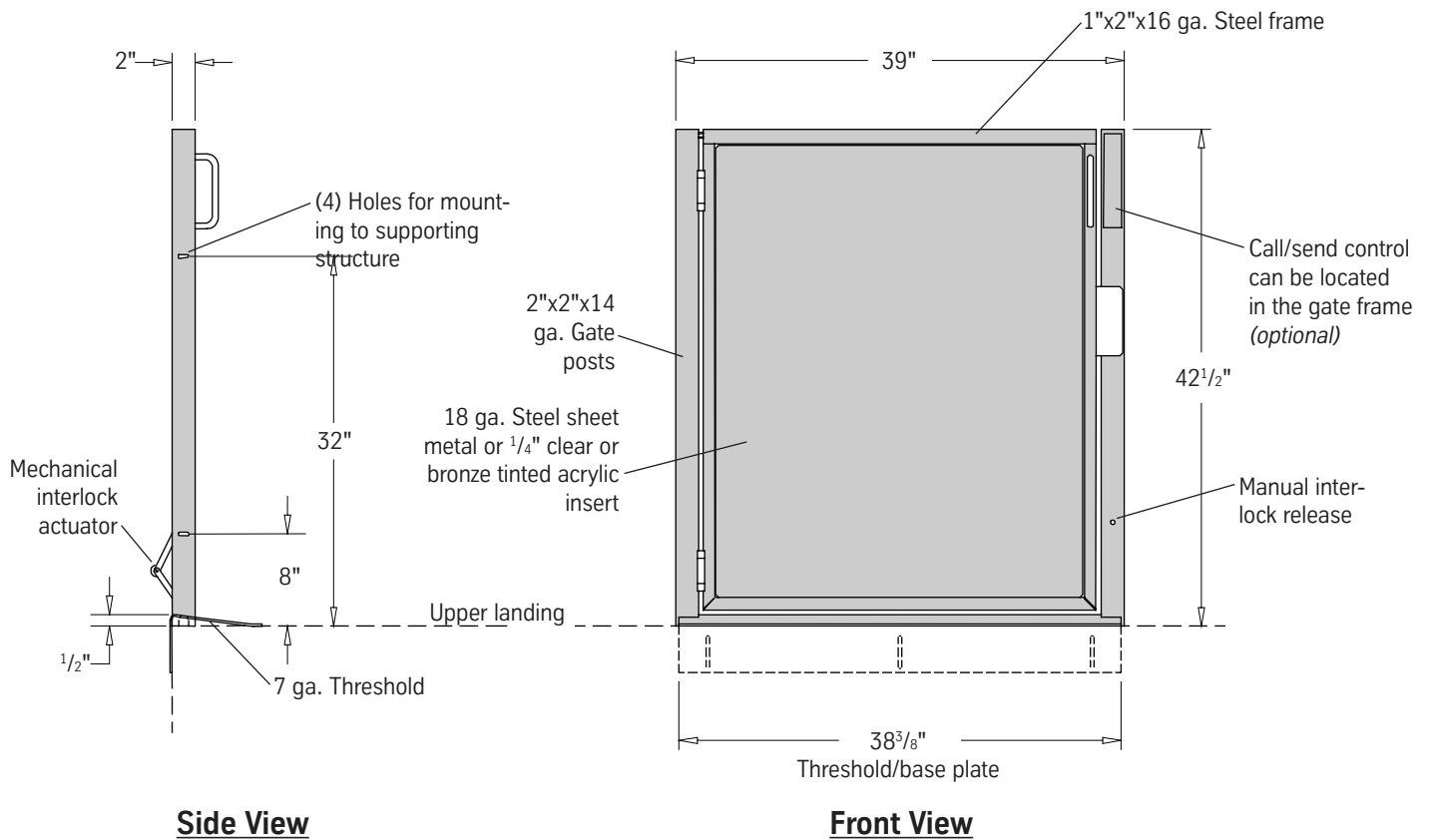
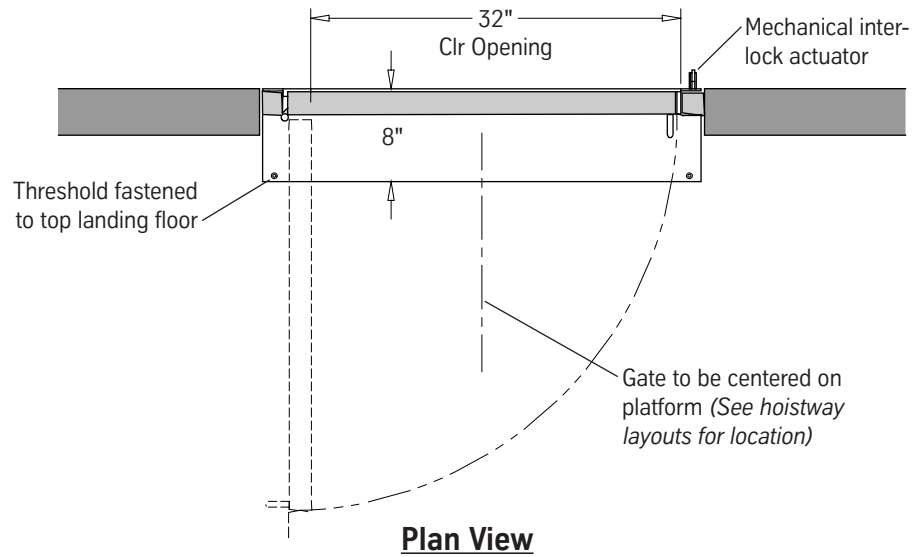

Mounting details

Floor anchor detail

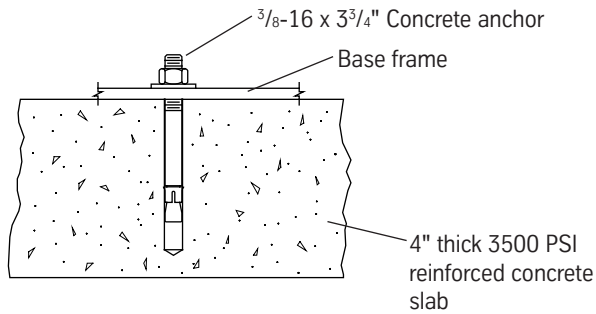

Base frame anchor locations

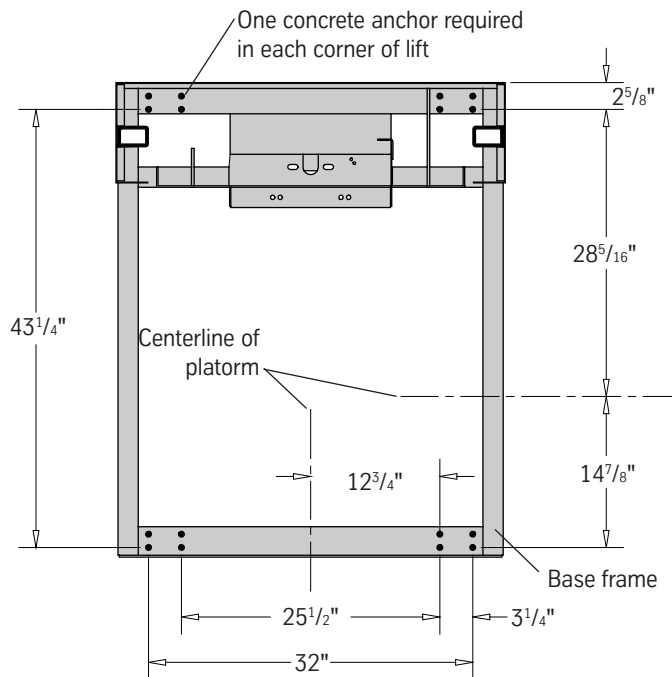

Machine tower anchor locations

If the lifting height of the unit is over 75", the machine tower must be anchored to a supporting structure at two points within 12" of the top of the tower.

Pull out force at top anchor*:

Model	LBF
PL-S 96	235
PL-S 120	191
PL-S 144	161
PL-S 168	139

* Top support located within 12" of the top of the machine tower. Does not include safety factor.

Static anchoring load calculations

Floor loading of PL-S with ballscrew drive

Ballscrew Drive Lift Model	Tower Weight T lbs	Car Weight C lbs	Payload Weight P lbs	Rear Support* R1 lbs	Front Support* R2 lbs	Top Support** R3 lbs	Minimum Support Hgt H inches	Uniform Floor Loading*** Footprint = 344 in. ² psi
PL-S 36	386	390	750	809	716			4.43
PL-S 50	424	390	750	845	719			4.54
PL-S 72	483	390	750	900	723			4.72
PL-S 96	548	390	750	961	727	524	75	4.91
PL-S 120	613	390	750	1021	732	397	99	5.10
PL-S 144	678	390	750	1082	736	320	123	5.28
PL-S 168	743	390	750	1142	741	267	147	5.47

Floor loading of PL-S with hydraulic drive

Hydraulic Drive Lift Model	Tower Weight T lbs	Car Weight C lbs	Payload Weight P lbs	Rear Support* R1 lbs	Front Support* R2 lbs	Top Support** R3 lbs	Minimum Support Hgt H inches	Uniform Floor Loading*** Footprint = 344 in. ² psi
PL-S 50	547	390	750	959	727			4.90
PL-S 72	641	390	750	1047	734			5.18
PL-S 96	743	390	750	1142	741	524	75	5.47
PL-S 120	846	390	750	1237	748	397	99	5.77
PL-S 144	948	390	750	1333	755	320	123	6.07
PL-S 168	1051	390	750	1428	762	267	147	6.37

Notes:

- * Assume point loads at front and rear of machine tower.
- * Divide total load per quantity of anchors.
- * Loads are in compression.
- ** Loads are in tension.
- ** Minimum safety factor of 4 recommended.
- *** Applicable only with level pad with no shims.

Calculations do not include forces due to wind, seismic loading or snow loading, and do not include forces due to acceleration.

Increasing support height (H) decreases R3 anchor load. Consult factory for details.

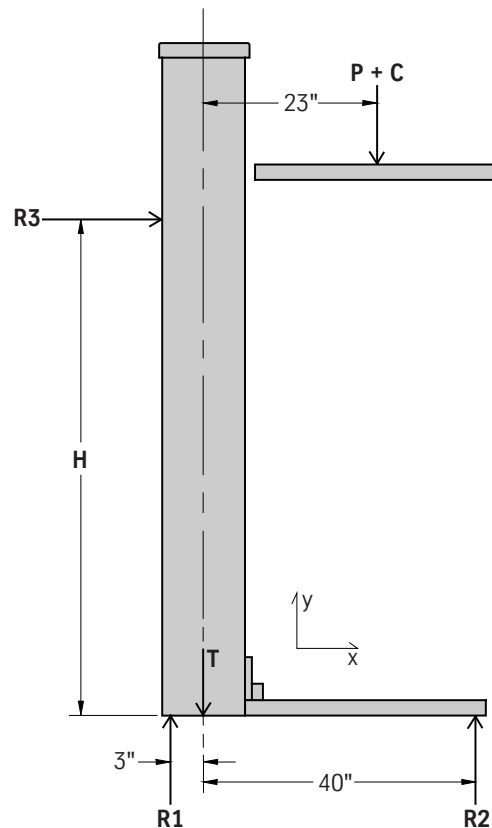

Features

Platform controls



Used to control the platform while riding on the platform.

- Constant pressure up and down paddle switch.
- Key switch with key removable in “off” position only.
- Emergency stop switch (push to ‘stop’, pull to ‘run’ operation) and signalling device. *Signalling device is an alarm that sounds when the emergency stop is activated.*
- Illuminated alarm button to sound the alarm at anytime.

Call/send controls

-Shown with optional Emergency Stop Switch and Surface Mount Box



Used to control the platform from a landing.

- Constant pressure up and down paddle switch.
- Can be provided with or without an emergency stop switch and signalling device. *Signalling device is an alarm that sounds when the emergency stop is activated.*
- Key switch with key removable in “off” position only.
- Shipped with a water tight black plastic box that can be surface mounted to a wall or can be flush mounted by recessing an electrical double gang box into the wall.
- Conduit and wires between control and the lift are to be provided by others.
- The call/send control can also be integrated into gates or doors.

Remote emergency lowering switch (optional on hydraulic drive only)



Used to lower the platform in the event of an emergency.

- To be located at the lower landing within sight of the platform.
- Constant pressure key switch; turn key to lower platform.
- Shipped with a watertight metal box that can be surface mounted to a wall or can be flush mounted by recessing an electrical gang box into the wall.
- All safety devices are disabled during operation of switch.
- Conduit and wires between control and the lift are to be provided by others.
- This is in addition to the standard manual emergency lowering relief valve.

Pit switch (optional)



Used to disable all controls while maintenance is being performed underneath the platform.

- Mounted to bottom of machine tower within arms reach of the lower landing door.
- Push to ‘stop’, pull to ‘run’ operation.

Grab rail



Used to assist a wheelchair user in maneuvering on the platform.

- Mounted on platform guard panel on machine tower side.
- Located 33" above platform floor.

Fixed access ramp



Used when the lift is mounted to the lower landing floor (vs. mounting inside a pit.)

- 1:12 slope.
- 43" wide x 31½" deep.
- Non-skid surface.

Note: Lower landing door must be blocked up 3" to accommodate the fixed access ramp.

AutoOpener™ (optional)



Automatically opens gate or door when platform stops at the landing.

- Mounts to wall near top of gate/door on the hinge side. Backing is required by contractor.
- Automatically reverses when an obstruction is encountered.
- If platform is already at the landing, gate/door can be opened by pressing call/send switch.
- Requires 115 VAC outlet near the top of the gate/door on the hinge side at each landing.

Battery disconnect (optional on hydraulic drive only)

Used to disable lift without disconnecting the batteries.

- Located inside the machine tower.

Telephone jack (optional)

Used to provide telephone service for the user in event of an emergency.

- Located near the platform controls.
- Telephone or ADA compliant equipment optional.

Optional colors

- The standard color for all equipment is ivory.
- Optional colors of sable brown, pearl gray or taupe are available.
- Special order colors (select from 180 RAL colors) are available at a premium. Download color chart at www.tkaccess.com/ral

SECTION 14420 WHEELCHAIR LIFTS

PART 1 GENERAL

1.01 SUMMARY

A. A vertical platform (wheelchair) lifting device, manufactured by ThyssenKrupp Access, designed to provide access to or within a building for mobility impaired persons. Lift consists of machine tower and lifting platform selected and dimensioned to provide adequate lifting height to suit building access requirements indoors and out.

1.02 REFERENCES

A. Lift shall be designed, manufactured and installed in accordance with the following standards:

1. American National Standards Institute (ANSI).
2. American Society of Mechanical Engineers (ASME).
3. ADA Accessibility Guidelines (ADAAG).
4. Underwriters Laboratories (UL).
5. International Building Code (IBC).
6. National Electrical Code (NEC).
7. American Society for Testing Materials (ASTM).
8. American Welding Society (AWS).

1.03 SYSTEM DESCRIPTION

A. Drive: (specify:)

1. AC powered ballscrew drive; 1/2 hp, 120 V, 60Hz, instant reversing motor.
2. Battery powered ballscrew drive; 1/2 hp, VDC, instant reversing motor with two 12 V, 33 AH, sealed no maintenance batteries with 24V 1.7 amp "smart charge" battery charger.
3. Battery powered 1:2 roped hydraulic drive; 3/4 hp, 24 VDC pump motor with two 12 V, 33 AH, sealed no maintenance batteries with 24 V 3.3 amp "smart charge" battery charger.

B. Number of Stops: (specify:) 2 stops or 3 stops.

C. Platform Configuration: (specify:) straight-thru, 90° exit or enter/exit same side.

D. Maximum Travel: (specify:) 39", 53", 75", 99", 123", 147" or 171".

E. Rated Load: 750 lbs. with minimum safety factor of 5X.

F. Rated Speed: 9-12 fpm (ballscrew drive) or 18-21 fpm (hydraulic drive) with rated load.

G. Platform Size: (specify:) 36"x48", 36"x56" or 36"x48" with 42" high guard panels.

H. Main Power Supply Wiring: Electrical contractor shall provide 115 VAC, single phase, 20 amp, 60 Hz power circuit.

J. Operating Features:

1. Platform Controls: Directional paddle switch, on/off key switch, emergency stop switch with alarm and illuminated alarm button.
2. Landing Controls: Directional paddle switch and on/off key switch (specify options:) emergency stop switch with alarm, mounted inside gate/door frames.
3. Constant pressure operation.
4. Grounded electrical system with upper, lower and final limit switches and 24 V operating controls.
5. Platform underpanel equipped with obstruction sensors.
6. Ramp with incline of 1:12 (required if lift is not installed in a pit).
7. Non-slip surface on platform floor and ramp.
8. Grab rail on platform.
9. Manual lowering device.

10. Remote emergency lowering switch (optional on hydraulic drive).

11. Integral ballscrew safety device and electromechanical brake (ballscrew drive).

12. Broken rope safety device and flow control valve (hydraulic drive).

13. Pit switch (where required by code).

14. Telephone jack on platform (optional).

15. Upper Landing Gate/Door: (specify:)

- a. 42" high, self-closing gate with VDR™ mechanical interlock and (specify:) steel sheet or acrylic insert panel.
- b. 6'-8" self closing, flush mount, 1-1/2 hour fire rated door with VDR™ mechanical interlock and 3"x26" glass vision panel.
- c. 6'-8" self closing, flush mount, non-fire rated door with VDR™ mechanical interlock and 27"x67" bronze tinted acrylic vision panel.
- d. 6'-8" self closing, flush mount, non-fire rated door with electric strike interlock and 27"x67" bronze tinted or clear acrylic vision panel.

16. Lower/Middle Landing Door: (specify:)

- a. 6'-8" self closing, flush mount, 1-1/2 hour fire rated door with VDR™ mechanical interlock and 3"x26" glass vision panel.
- b. 6'-8" self closing, flush mount, non-fire rated door with VDR™ mechanical interlock and 27"x67" bronze tinted acrylic vision panel.
- c. 6'-8" self closing, flush mount, non-fire rated door with electric strike interlock and 27"x67" bronze tinted or clear acrylic vision panel.

17. Automatic Gate/Door opener (optional).

1.04 QUALITY ASSURANCE

A. Manufacturer: Provide wheelchair lift manufactured by a firm with a minimum of 25 years experience in fabrication of wheelchair lifts equivalent to those specified.

B. All designs, clearances, workmanship and material, unless specifically excepted, shall be in accordance with all codes having legal jurisdiction.

C. All load ratings and safety factors shall meet or exceed those specified by all governing agencies with jurisdiction and shall be certified by a professional engineer.

D. Lift shall be subject to applicable state, local and city approval prior to installation and subject to inspection after installation. Determination of and adherence to these regulations is the responsibility of the lift contractor.

E. Welders certified in accordance with requirements of AWS D1.1 shall perform all welding of all parts.

F. Substitutions: No substitutions permitted.

1.05 WARRANTY

A. Manufacturer shall warrant the Porch-Lift® vertical platform lift's drive system for a period of two years after installation and all other components for one year after installation.

B. Extended Warranty (optional): Manufacturer shall warrant the Porch-Lift® vertical platform lift for a period of (specify:) 3 or 5 years after installation with the purchase of a preventative maintenance program from lift contractor for an equal number of years.

1.06 MAINTENANCE

- A. The Porch-Lift® vertical platform lift must be maintained in accordance with manufacturer's instructions.

PART 2 PRODUCT

2.01 MANUFACTURER

- A. Provide Porch-Lift® vertical platform lift model PL-S manufactured by ThyssenKrupp Access.
 - 1. Contact: 4001 E. 138th Street, Grandview, MO; Telephone: 800-925-3100; Fax: 816-763-4467; Email: archassist@accessind.com; Web site: www.tkaccess.com

2.02 MATERIAL

- A. Machine Tower: 14 ga. steel sheet.
- B. Guide Rail: 3" x 2" x 1/8" ASTM A500 grade B steel tubing.
- C. Base Frame: 2" x 2" x 1/4" structural steel tubing and angle.
- D. Lift Weldment: 3/8" hot rolled steel plate and 2" x 2" x 1/4" wall structural steel tubing.
- E. Side Guard Panels: 18 ga. galvanealed steel sheet in 1" x 2" x 14 ga. steel tubing frame.
- F. Front Access Panel: 20 ga. galvanealed steel sheet.
- G. Platform: 11 ga. steel plate.
- H. Access Ramp: 11 ga. steel plate.

2.03 FINISHES

- A. Components shall be prepared with 1)alkaline detergent wash, 2) clear water rinse, 3) iron phosphate coating, 4) clear water rinse and finished with electrostatically applied and baked thermostatic powder coat finish for indoor or outdoor use. Standard color is ivory.

2.04 ELECTRICAL SYSTEMS

- A. The electrical contractors shall provide a 115V, single phase, 20 amp, 60 Hz electrical power source connection.
- B. Electrical piping and wiring supplied by others.
- C. Final electrical connections performed by lift contractor.

PART 3 EXECUTION

3.01 ACCEPTABLE INSTALLERS

- A. Installers shall be experienced in performing work of this section who have specialized in work comparable to that required for this project.
- B. Installers shall be certified and trained by the manufacturer.

3.02 EXAMINATION

- A. Use field dimensions and approved manufacturer's shop drawings to examine substrates, supports and other conditions under which this work is to be performed. Do not proceed with work until unsatisfactory conditions are corrected.

3.03 INSTALLATION

- A. The Porch-Lift® vertical platform lift shall be installed in accordance with manufacturer's instructions and as specified and approved by architect.
- B. Landing gates and doors shall be installed by others. Electrical piping and wiring by others. Final electrical connections and lift adjustments by lift contractor.

3.04 DEMONSTRATION

- A. The lift contractor shall make a final check of the lift's operation with the Owner or Owner's representative present prior to turning the lift over for use. The lift contractor shall determine that operating and safety devices are functioning properly.

END OF SECTION

Notes: Go to www.tkaccess.com to download this specification in CSI format.

Intent of specification is to broadly outline equipment required but does not cover details of design and construction.

Dimensions and specifications are subject to constant change and continually evolving codes and product applications. For additional technical information, contact ThyssenKrupp Access at 800-925-3100 or www.tkaccess.com.

ThyssenKrupp Access
4001 East 138th Street
Grandview, MO 64030-2837
Phone: 816-763-3100
Fax: 816-763-4467
Sales: 800-669-9047
www.tkaccess.com